

BROADBAND NETWORKS

ATM 2228

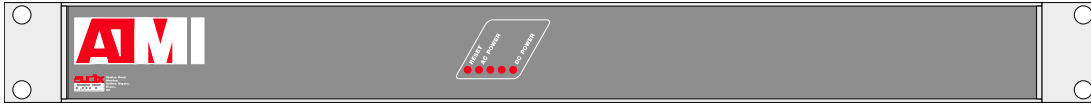

ATM System

Audix Broadcast has developed a single wide area network system for use in broadcasting. The system allows Real Time No Compromise Linear audio and remote control interfaces to be passed over the network. The carrier infrastructure uses known, tested and now standard telecom technologies to provide very robust wide area networks.

There are NO restrictions on sampling frequencies or word sizes, mono and stereo, surround sound or even MADI may be passed over the same networks.

The gateway interfaces can be stand alone or integrated into our digital audio mixers, and provide a simple and elegant method of implementing a wide area audio routing and control system. The system is infinitely expandable and includes the capability of linking studios on different sites through standard telecom network connections.

The ATM series of Broadband interface units allow the customer to choose the model most suited to the application. All

the series are compatible and conform to the recently published (AES47) standard for ATM based audio transport products.

The more comprehensive units offer the choice of analogue or digital audio ports.

Each ATM frame has local status outputs which are supplied as "closing contacts" for feeding to other systems and include DC Power "OK", Software Status "OK", Polling "OK", Broadband Link "OK" and AES Sync "OK".

Each ATM frame has a number of static logic interfaces which may be programmed for either local or remote cues over the network. The local controller is also accessed by a "higher authority" through the ATM network which allows each ATM frame to operate as part of a wide area system without the need of any additional cabling/interfaces.

The ATM frames may be linked and controlled with our ANTS computer system providing customers with a totally integrated Broadcast Solution.

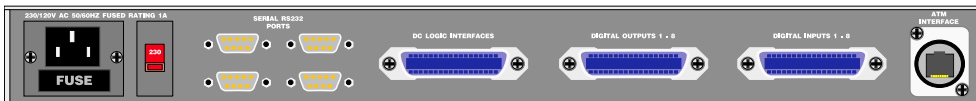

This gateway provides all the necessary facilities and services to operate as a main transmission routing and control system. The system allows for audio mixing from three sources. Two of which are derived from the atm network. The third from either an emergency digital AES input or from other local sources.

In the event of a failure either a local control via an RS232 source or network control system can override the ATM audio with this local source. The frame includes other facilities required for transmission routing including silence detectors, various monitor feeds and the ability to insert various third party processing systems.

- Linear 24bit real time audio transmission system
- Non blocking network topology
- Common network carrying audio control and computer data
- Simple and low cost installation
- No restrictions on size of network
- Open structures to AES47 standard
- 8 Digital AES inputs
- 8 Digital AES outputs
- Logic control of inputs and outputs
- Full remote reporting system
- Closed loop control system
- Front panel status indicators
- Connection to external audio and logic interfaces via multiway connectors



SPECIFICATION: ATM2228

Maximum No. of Inputs Up to 8 Stereo channels
 Digital Inputs Transformer isolated, AES/EBU format, 48kHz Sampling, Synchronous
 Maximum No. Outputs Up to 8 stereo channels
 Digital Outputs Transformer isolated, AES/EBU format, 48kHz Synchronous
 External Synchronisation AES/EBU silence
 Dynamic Range 130dB
 Frequency Response +/- 1dB, 20Hz to 20kHz any input to any output
 Distortion Less than 0.03%, any input to any output
 Crosstalk Not measurable
 Maximum Output +18dBu = 0dBFS, as standard
 Digital Resolution Selectable as 16, 18, 20 or 24 bit

ATM Gateway 25MB Port Connection
 Audio Circuits 8 stereo linear digital audio, 48kHz, 24bit samples
 DC Control-Data Slow Speed serial RS232 possible, data will be interleaved with control message structure, no guaranteed bandwidth available.

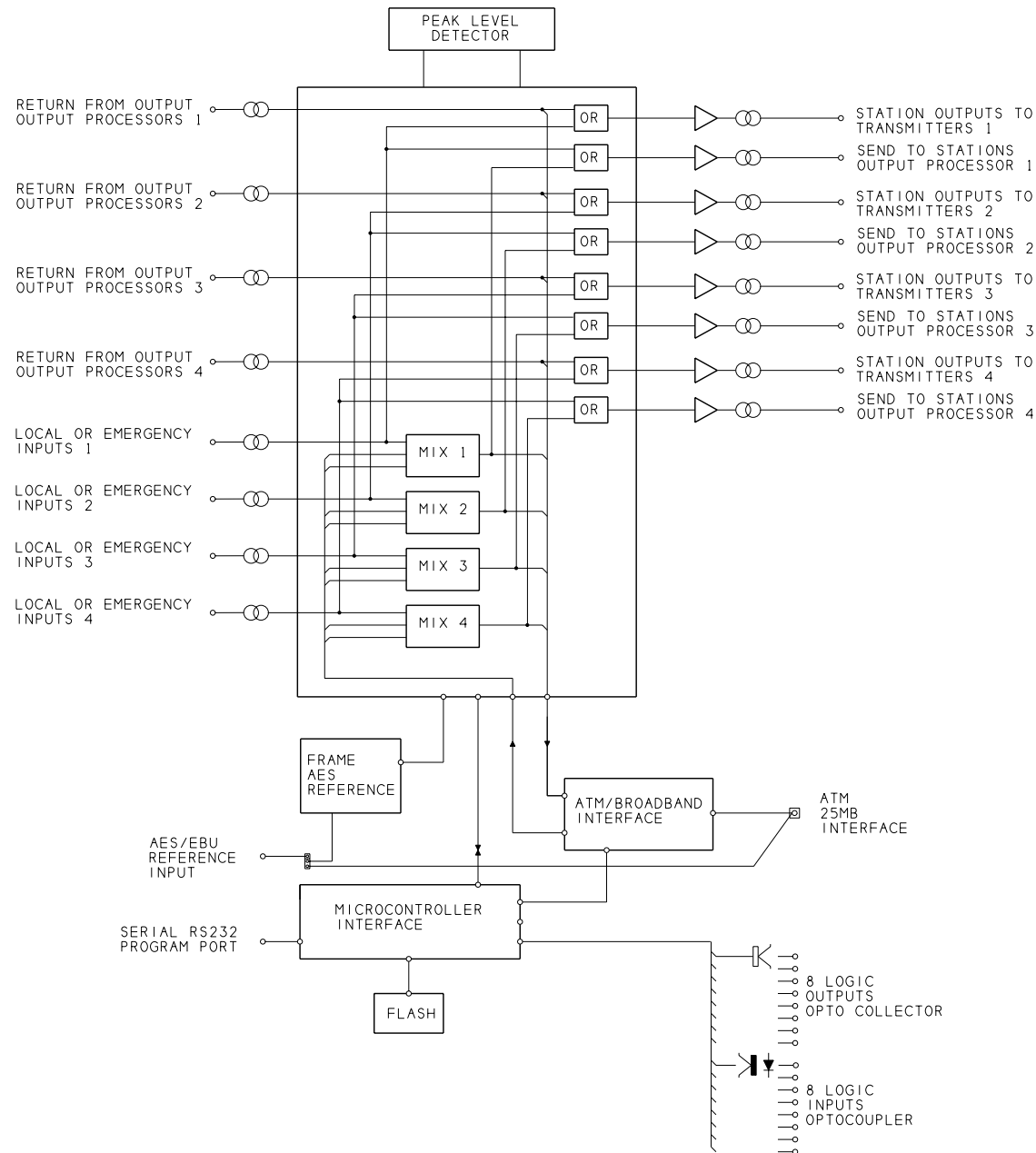

WHAT IS ATM

ATM is a world-wide Telecom standard for the transfer of any digital data, ATM networks are scaleable and offer different levels of service for different types of service. Where ATM technology is used in a local area networks at present the most common data rates are 25,155 and 622Mbits/sec.

ATM is a cell based transmission structure and is the only infrastructure where users can request and receive different qualities of service over the network. The common network is capable of carrying signals/data for audio, video and standard IP traffic.

Constant bit rate ATM network circuits are used in real time linear audio applications and can be set-up for either one to one or one to many "multicasting" for distribution/monitoring, ATM networks have very low latency and are ideal for live audio use, typical delays of less than 8mS end to end for a 600KM distance.

Audix Broadcast's current Gateway interface runs on the 25Mbit/sec rate and provides users with access ports for up to 8 individual stereo 48Hz 24bit linear audio circuits in both directions as well as parallel and serial control ports.

WARRANTY

All equipment is guaranteed for a period of twelve months against faulty workmanship and materials. All repairs are to be carried out at our works at Saffron Walden, where units must be forwarded, carriage paid. We reserve the right to exchange or replace units as necessary.

DEVELOPMENT

Audix Broadcast policy is one of continuous improvement. We reserve the right to change specifications without notice. Typical figures are based on normal operating conditions. For critical applications please confirm current specifications with our sales department.