

BROADBAND NETWORKS

ATM 2224

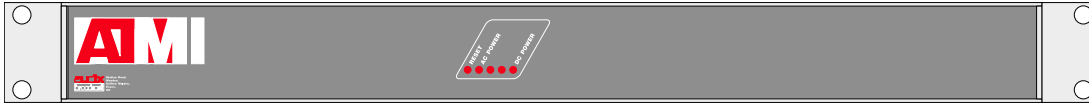

ATM System

Audix Broadcast has developed a single wide area network system for use in broadcasting. The system allows Real Time No Compromise Linear audio and remote control interfaces to be passed over the network. The carrier infrastructure uses known, tested and now standard telecom technologies to provide very robust wide area networks.

There are NO restrictions on sampling frequencies or word sizes, mono and stereo, surround sound or even MAD1 may be passed over the same networks.

The gateway interfaces can be stand alone or integrated into our digital audio mixers, and provide a simple and elegant method of implementing a wide area audio routing and control system. The system is infinitely expandable and includes the capability of linking studios on different sites through standard telecom network connections.

The ATM series of Broadband interface units allow the customer to choose the model most suited to the application. All the series are compatible and conform to

the recently published (AES47) standard for ATM based audio transport products. The more comprehensive units offer the choice of analogue or digital audio ports.

Each ATM frame has local status outputs which are supplied as "closing contacts" for feeding to other systems and include DC Power "OK", Software Status "OK", Polling "OK", Broadband Link "OK" and AES Sync "OK"

Each ATM frame has a number of static logic interfaces which may be programmed for either local or remote cues over the network. The local controller is also accessed by a "higher authority" through the ATM network which allows each ATM frame to operate as part of a wide area system without the need of any additional cabling/interfaces.

The ATM frames may be linked and controlled with our ANTS computer system providing customers with a totally integrated Broadcast Solution.

- Digital Audio Gearbox, conversion rates from 32 to 96kHz
- Common network carrying audio control and computer data
- Simple and low cost installation
- Open structures to AES47 standard
- Logic control of inputs and outputs
- Full remote reporting system
- Closed loop control system
- Front panel status indicators

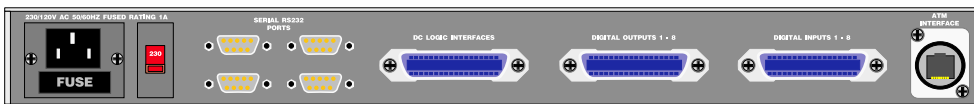

Known as the Audio Gearbox the ATM 2224 frame allows the system to operate on digital sample rates up to 96kHz (at present).

Typical applications would be to synchronise with the station's standard 48kHz reference to any "wild sources" which may come in over the network.



SPECIFICATION: ATM 2224

Maximum No. of Channels	Up to 4 stereo channels
Digital Inputs	Transformer isolated, AES/EBU format, inputs include Sample Rate Conversion, rates 32 to 96kHz possible
Maximum No. Outputs	Up to 4 stereo channels
Digital Outputs	Transformer isolated, AES/EBU format
External Synchronisation	AES/EBU silence
Dynamic Range	Better than 110dB
Frequency Response	+/- 1dB, 20Hz to 20kHz any input to any output
Distortion	Less than 0.3%, any input to any output
Maximum Output	+18dBu = 0dBFS, as standard
Digital Resolution	Selectable as 16, 18, 20 or 24 bit

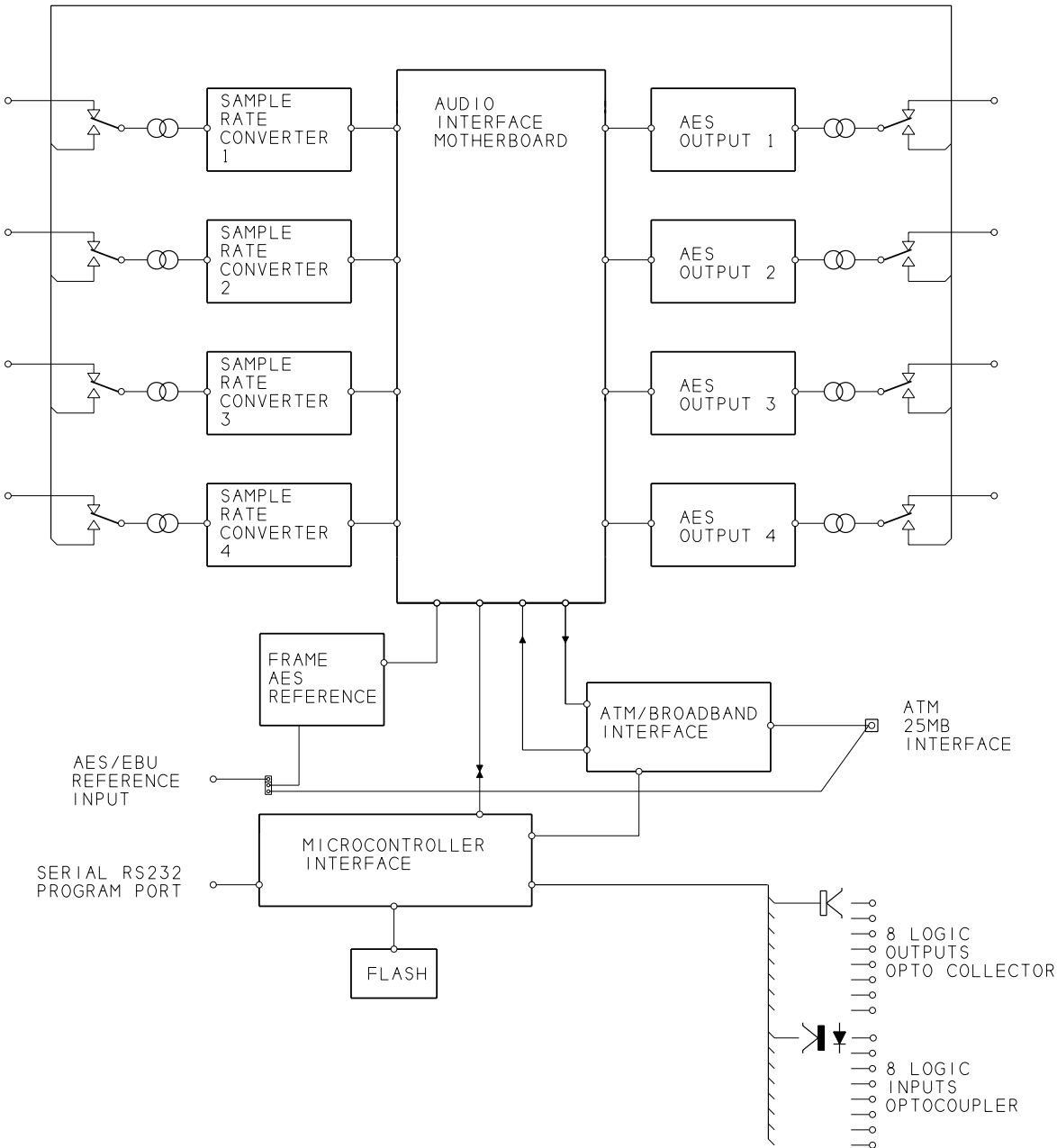

WHAT IS ATM

ATM is a world-wide Telecom standard for the transfer of any digital data, ATM networks are scaleable and offer different levels of service for different types of service. Where ATM technology is used in a local area networks at present the most common data rates are 25,155 and 622Mbits/sec.

ATM is a cell based transmission structure and is the only infrastructure where users can request and receive different qualities of service over the network. The common network is capable of carrying signals/data for audio, video and standard IP traffic.

Constant bit rate ATM network circuits are used in real time linear audio applications and can be set-up for either one to one or one to many "multicasting" for distribution/monitoring, ATM networks have very low latency and are ideal for live audio use, typical delays of less than 8mS end to end for a 600KM distance.

Audix Broadcast's current Gateway interface runs on the 25Mbit/sec rate and provides users with access ports for up to 8 individual stereo 48Hz 24bit linear audio circuits in both directions as well as parallel and serial control ports.

WARRANTY

All equipment is guaranteed for a period of twelve months against faulty workmanship and materials. All repairs are to be carried out at our works at Saffron Walden, where units must be forwarded, carriage paid. We reserve the right to exchange or replace units as necessary.

DEVELOPMENT

Audix Broadcast policy is one of continuous improvement. We reserve the right to change specifications without notice. Typical figures are based on normal operating conditions. For critical applications please confirm current specifications with our sales department.